

China PEOPLE pneumatic component

Pneumatic valve , Solenoid valve , Pneumatic component , China Pneumatic, Cylinders

- [PEOPLE Pneumatic](#)
- [Product](#)
- [Valves](#)
- [Cylinder](#)
- [Pneumatic Component](#)
- [Air Preparation](#)
- [Pneumatic accessories](#)
- [News](#)
- [Tech Support](#)
- [Contact Us](#)

STM Series Slide Cylinder

[Pneumatic cylinder](#) >> [STM Slide Cylinder](#)



View technical date of STM Series Slide Cylinder with PDF

Stm series slide cylinders

Series code: **STM**

Bore size:

10:10mm 16:16mm 20:20mm 25:25mm

Stroke: 100

Mounting Type:

B: Body mounting

C: Side mounting

Order code for STM Series Slide Cylinder



STM

Series Code
STM:
STM series Slide Cylinder

B

Mounting Type
B: Body Mounting
S: Slide Mounting

—

25

Bore Size
10:10mm
16:16mm
20:20mm
25:25mm

×

100

Stroke

Specifications for STM Slide Cylinder

Bore (mm)	10	16	20	25
Action Mode	Duo-Piston Double Action Type			
Medium	Air			
Working Temp. (°C)	-5-70			
Working Press. Range(MPa)	0.1~0.9			
Proof Press.(MPa)	1.0			
Working speed (mm /s)	50-200			
Adjustable Stroke(mm)	-10-0			
Cushion Type	N/A	Oil Press. bumper(Optional)		
Lubrication	Not required			
Non-rotate tolerance	±0.1°			±0.05°
Port Size	M5x0.8			1/8

Stroke for STM Series Slide Cylinder

Pneumatic equipment directory

- [PEOPLE group](#)
- [Product introduction](#)
- [Pneumatic components](#)
- [Pneumatic valves](#)
- [Solenoid valve](#)
- [Pneumatic cylinders](#)
- [Air preparation](#)
- [Pneumatic Fittings](#)
- [Pneumatic accessories](#)
- [Pneumatic equipments](#)
- [Pneumatic parts](#)
- [Industry News](#)
- [Technical support](#)
- [Pneumatic standards](#)
- [Events](#)
- [Contact Us](#)

People website search

Pneumatic products

- [S Air Treatment Component](#)
- [A Air Treatment Component](#)

New products

STMB-20

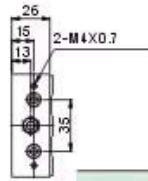
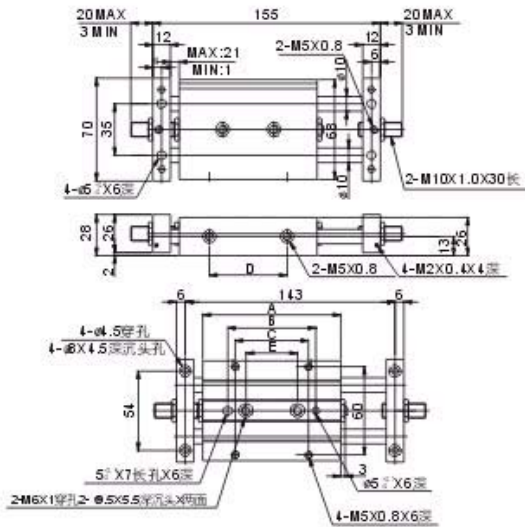

Code /Stroke	A	B	c	D	E
25	94	60	50	53	35
50	119	85	50	78	45
75	144	110	75	103	45
100	169	135	100	128	70
125	194	150	120	153	90
150	219	150	120	178	90
175	244	150	120	203	90
200	269	150	120	228	90
250	319	150	120	278	90

STMB-25

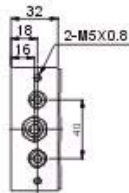
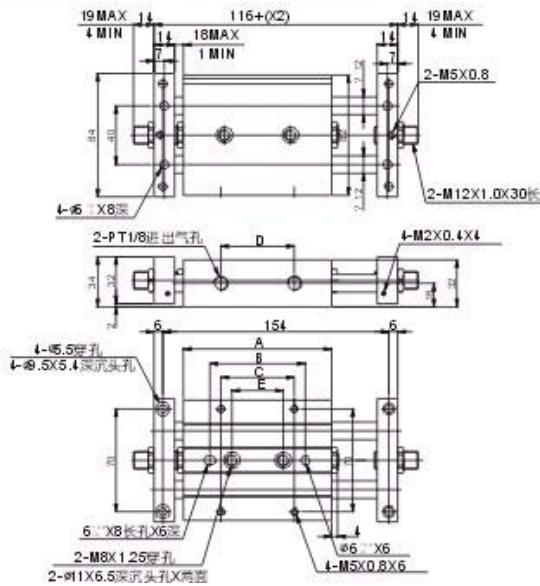

Code /Stroke	A	B	c	D	E
25	101	65	50	50	35
50	126	90	50	75	45
75	151	115	75	100	45
100	176	140	100	125	70
125	201	140	100	150	95
150	226	140	100	175	100
175	251	140	100	200	100
200	276	140	100	225	100
250	326	140	100	175	100

STMS-10

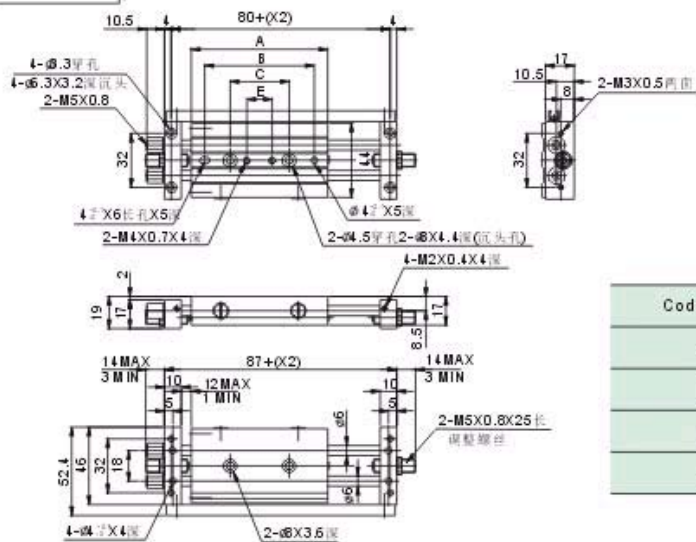

Code/Stroke	25	50	75	100
A	81	106	131	156
B	65	85	85	85
C	35	60	60	60
E	15	40	40	40

STMS-16

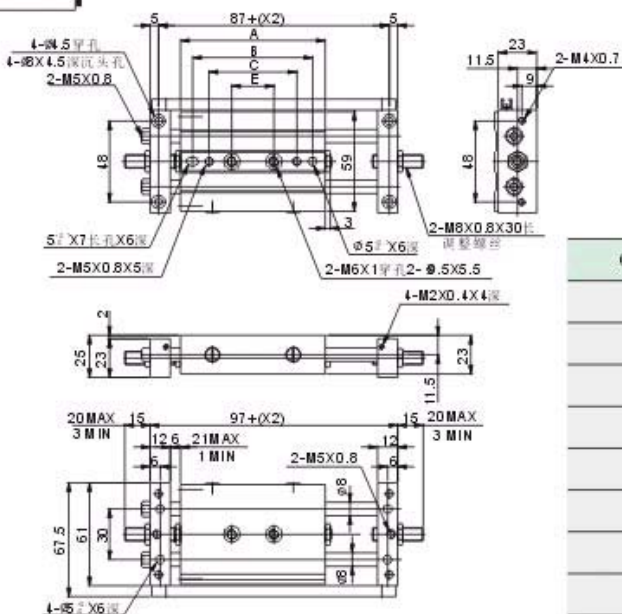

Code/Stroke	A	B	C	D	E
25	86	55	—	48	25
50	111	80	—	73	50
75	136	105	75	98	45
100	161	130	100	123	70
125	186	150	120	148	90
150	211	150	120	173	90
175	236	150	120	198	90
200	261	150	120	223	90

